



FREE STANDING TOWEL RACK INSTALLATION GUIDE

FOR MODERN HOME CREATORS

CUSTOMER SERVICES

keshome.com

cs@keshome.com



CHAT NOW

After-sale Service



24- Hour Customer Support

Visit our customer support center at www.keshome.com/cs, available 24/7.
Contact us via Amazon Message, instant chat, and email during business hours.



Free Replacement Parts

Please contact us if any parts are damaged or missing. Parts provided free. (Shipping fees may apply)



1-on-1 Responsive Customer Service

No need to restate your case with each contact. Our dedicated team of professionals will work on resolving your issue until it is resolved.



Parts Customization

No need to worry about unexpected challenges. Share your requirements, and we'll customize parts to meet your specific needs.



Return Policy

Feel free to return within 30 days. Please ensure all items (particularly the hardware pack) are in the box before returning.

Missing Return Window?

No Worry!
We totally understand



Contact us
Replace for FREE

PRODUCT COMPONENTS

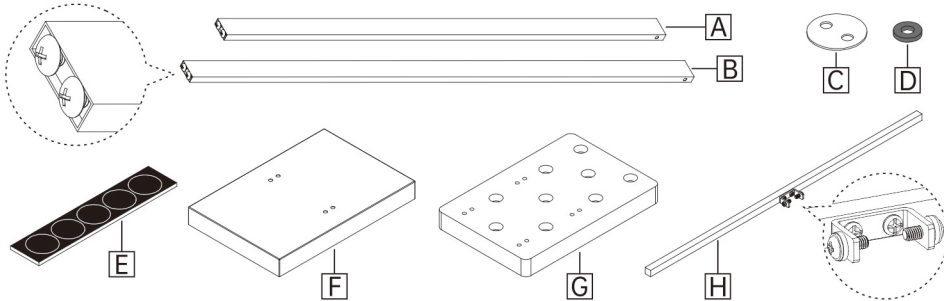

Parts List:

- | | | | |
|-------------------|----------------------|-------------------------------|--------------|
| A. Short Bar (x1) | C. Metal Washer (x2) | E. Anti-slip Pad (x1) | G. Base (x1) |
| B. Long Bar (x1) | D. Washer (x4) | F. Stainless Steel Cover (x1) | H. Bar (x2) |

HELPFUL TOOLS



Screwdriver

INSTALLATION

1

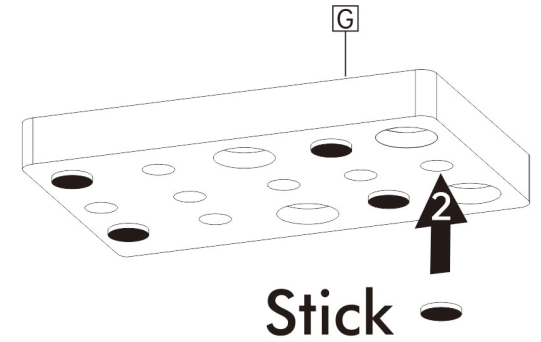
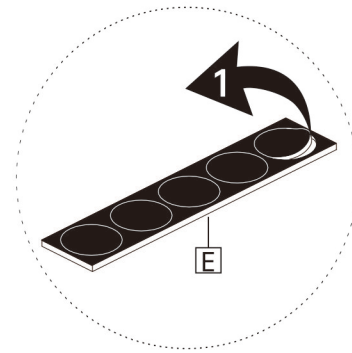

Stick

2

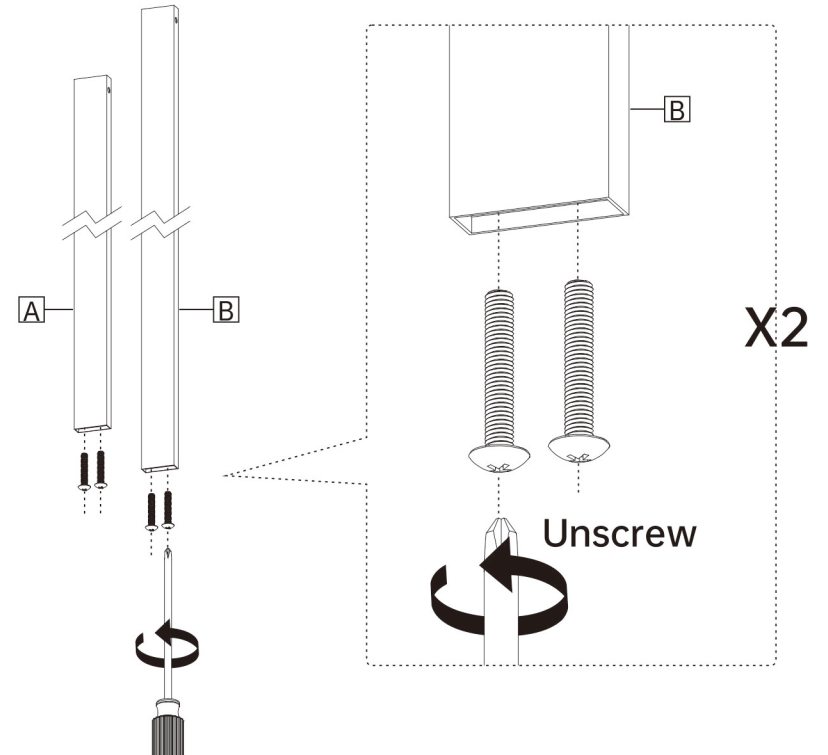

X2

Unscrew

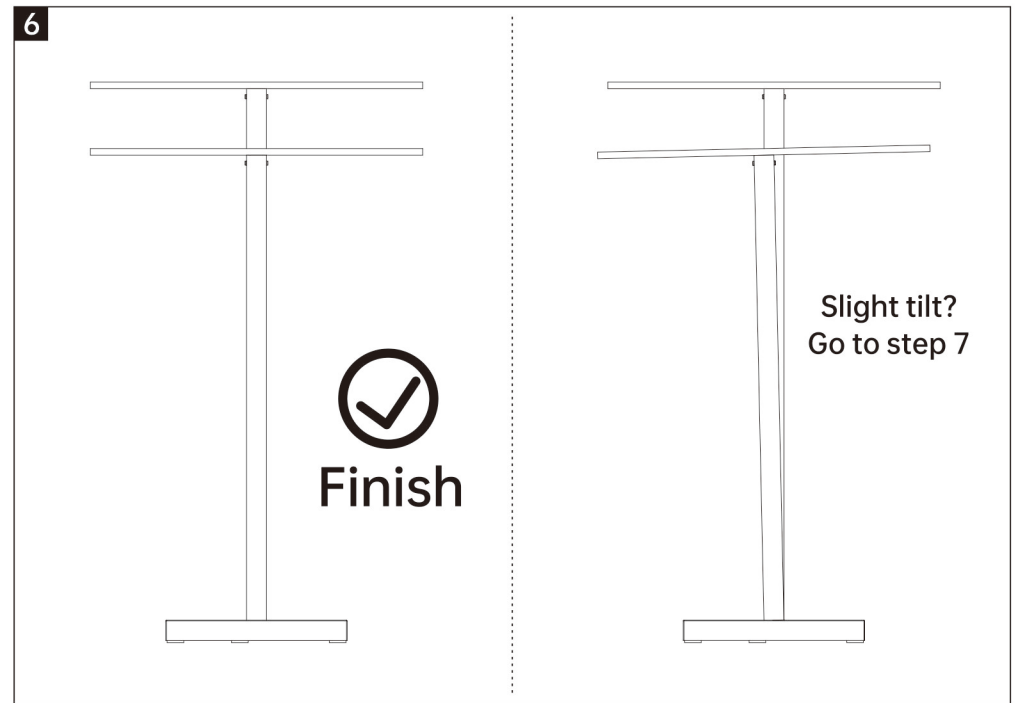
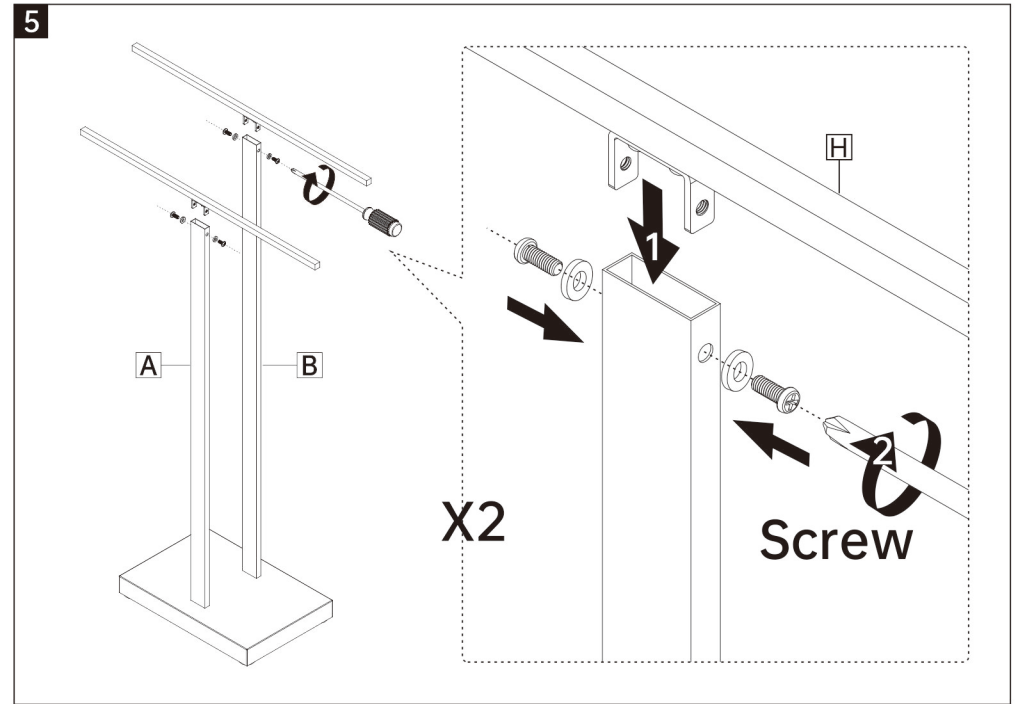
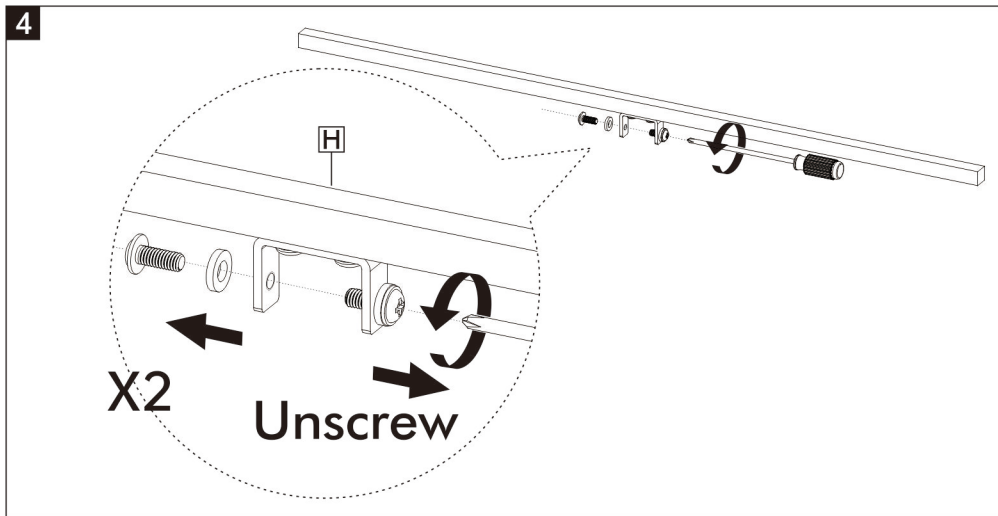
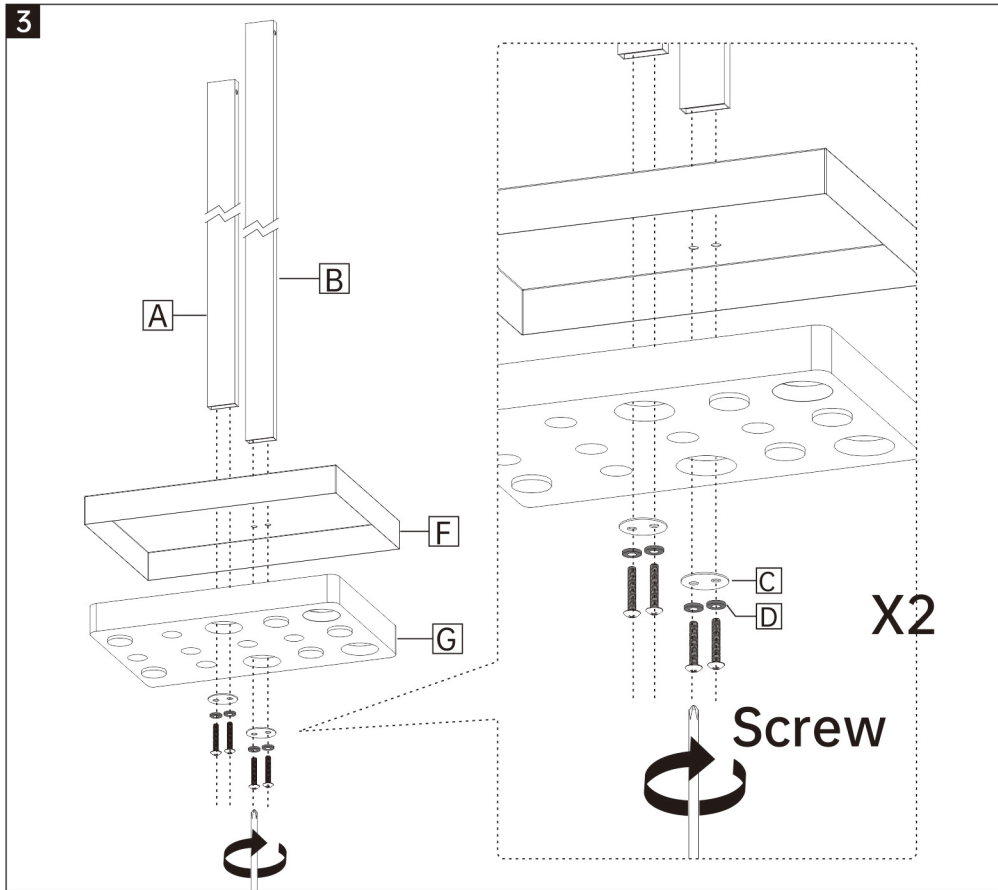

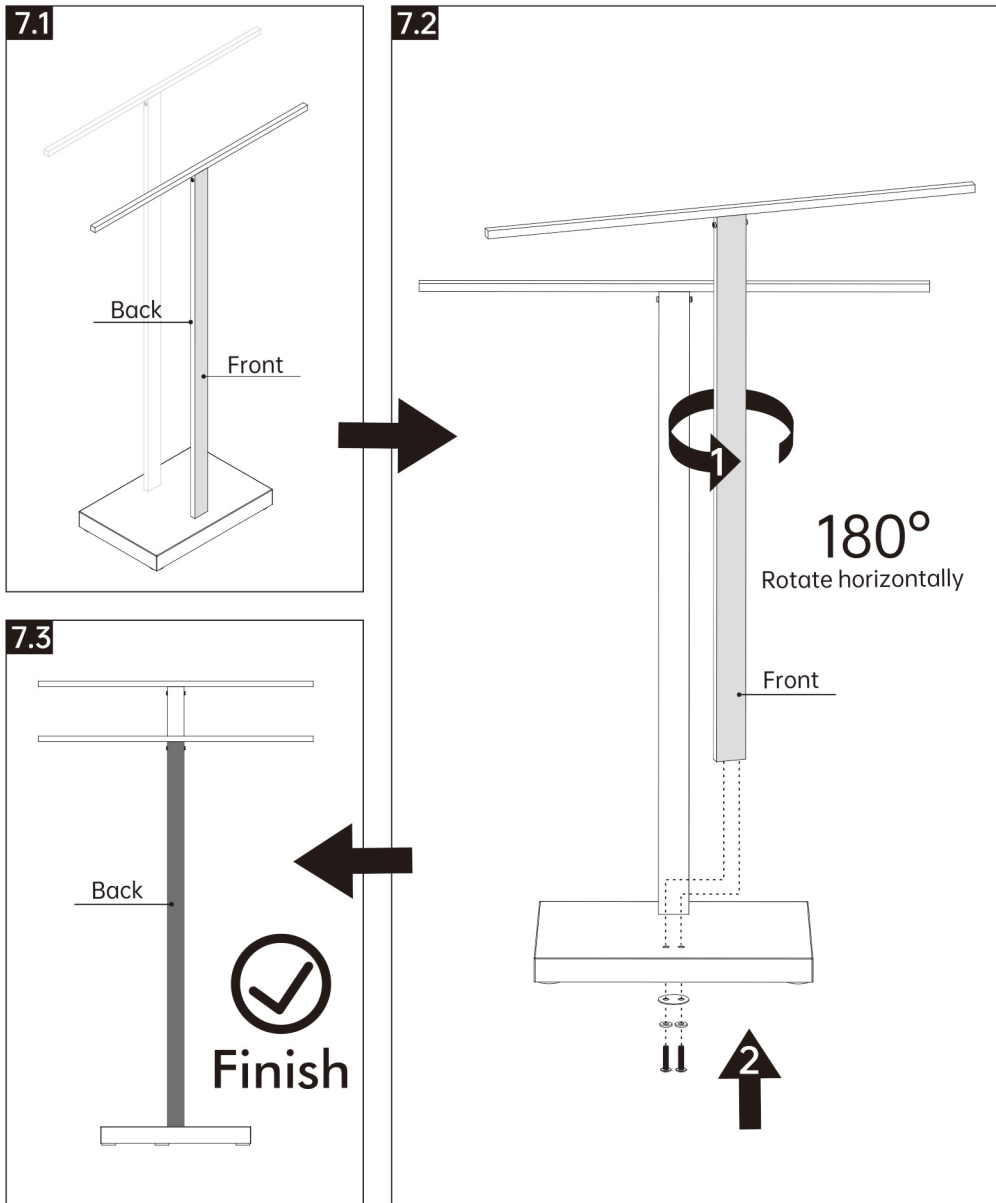

Still tilt? Contact us!

Replace for FREE
cs@keshome.com

CHAT NOW

One-Year Limited Warranty

KES warrants its products purchased from authorized sellers to be free from defects in material and workmanship for one (1) year from the original date of purchase.

What We Will Do

KES will repair or replace, FREE OF CHARGE, during the one (1) year warranty period, any part that proves defective in material and/or workmanship under normal installation, use and service. If repair or replacement is not practical, KES may elect to refund the purchase price in exchange for the return of the product.

What Is Not Covered

KES shall not be liable for any damage to the product resulting from reasonable wear and tear, installation and maintenance errors, outdoor use, freezing water, abuse, misuse, and use of cleaners containing abrasive cleansers, ammonia, bleach, acids, waxes, alcohol or other organic solvents.

KES is not responsible for removal, installation, labor charges, or other incidental or consequential costs. In no event shall the liability of KES exceed the purchase price of the product.

KES AND/OR SELLER ARE PROVIDING THESE WARRANTIES IN LIEU OF ALL OTHER WARRANTIES, EXPRESSED OR IMPLIED, INCLUDING BUT NOT LIMITED

TO THE IMPLIED WARRANTIES OF MERCHANTABILITY AND FITNESS FOR A PARTICULAR PURPOSE. KES AND/OR SELLER DISCLAIM ALL LIABILITY FOR SPECIAL, INCIDENTAL OR CONSEQUENTIAL DAMAGES.

Some jurisdictions do not allow the exclusion or limitation of incidental or consequential damages, so these limitations and exclusions may not apply to you. This warranty gives you specific legal rights and you may also have other rights which vary from jurisdiction to jurisdiction.

This warranty applies only to KES products sold in North America and Europe.

Contact KES

Email: cs@keshome.com

Online Contact:



Please provide:

- dated proof of purchase
- description of the defect/fault
- picture or video showing the issue(s) (optional)



FR

Pensez à donner ou recycler.



Association

ou



Magasin

ou



Déchèterie