

SHOWER SYSTEM INSTALLATION GUIDE

XB6245

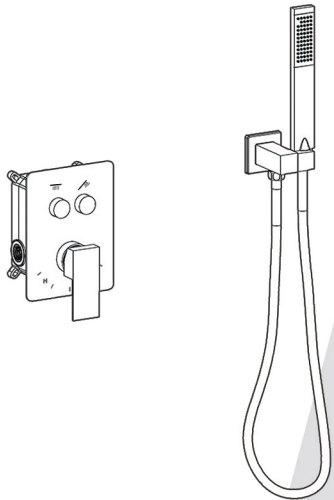
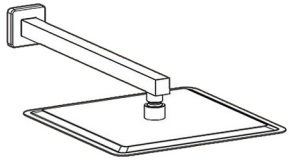

WARNING

This shower system is NOT designed for outdoor use. To reduce the risk of injury or property damage, read and follow all the installation instructions before installing this product. Wear safety goggles. This product must be installed in accordance with all state and local plumbing and building codes. Call a professional if you are uncertain about installing this product properly.

CUSTOMER SERVICES

cs@keshome.com



CHAT NOW

XB6245S12.V3.0

ILLUSTRATED PARTS

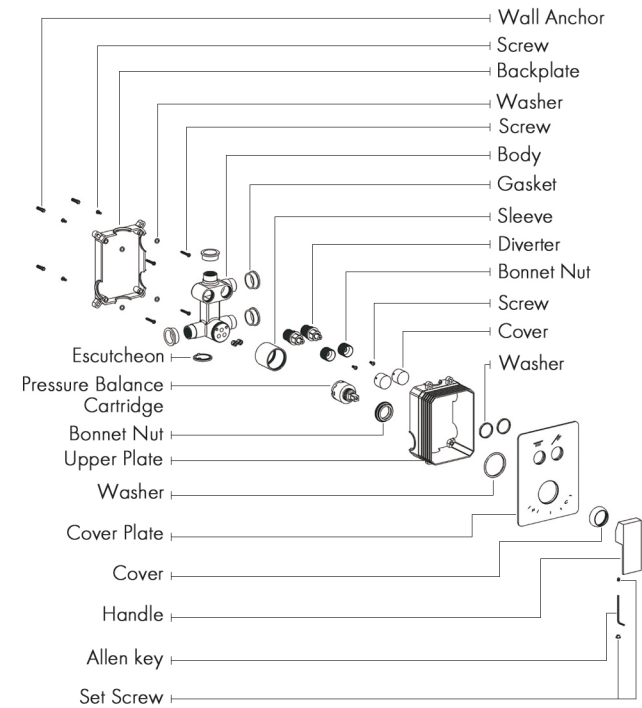
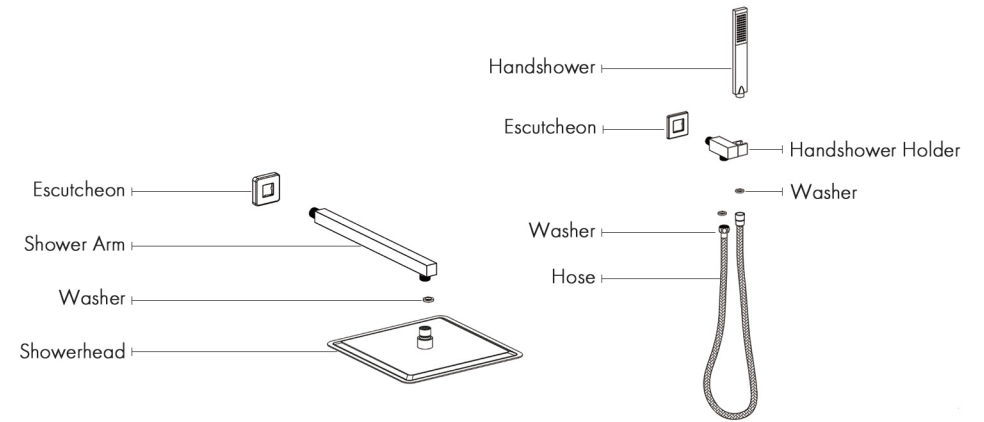

WORKING CONDITIONS

Environment Temperature: 5°C-49°C (41°F-120°F)
 Inlet Water Temperature: 5°C-70°C (41°F-158°F)
 Water Pressure: 0.15MPa-0.50MPa
 Plumbing Connection : 1 / 2 " -14 NPT
 Showerhead Thread Size : G1 / 2 "

RECOMMENDED TOOLS

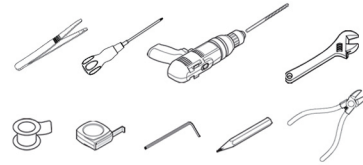

DIMENSIONS

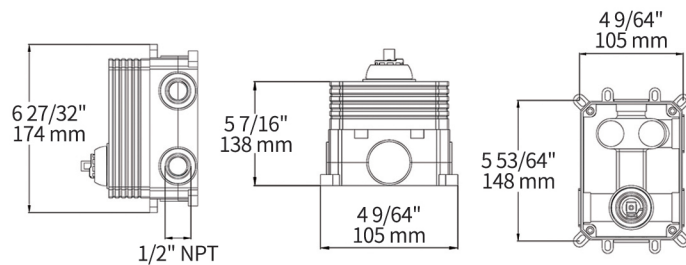
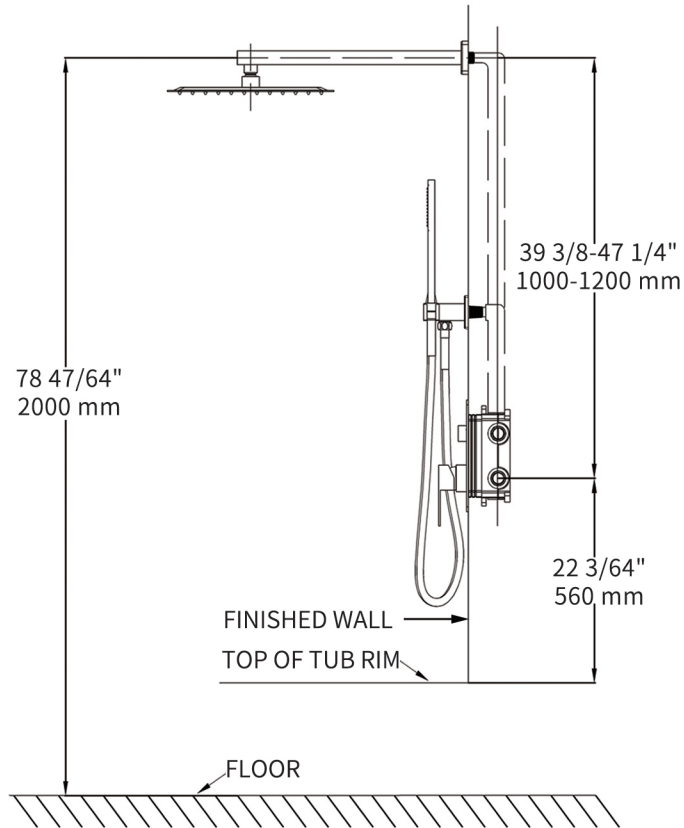

Valve Box's Distance Adjustment

The maximum distance between the stringer and the front surface of finished wall is 3 5/32", and the minimum distance is 2 61/64". The Recommended Distance is 2 61/64" for installation.

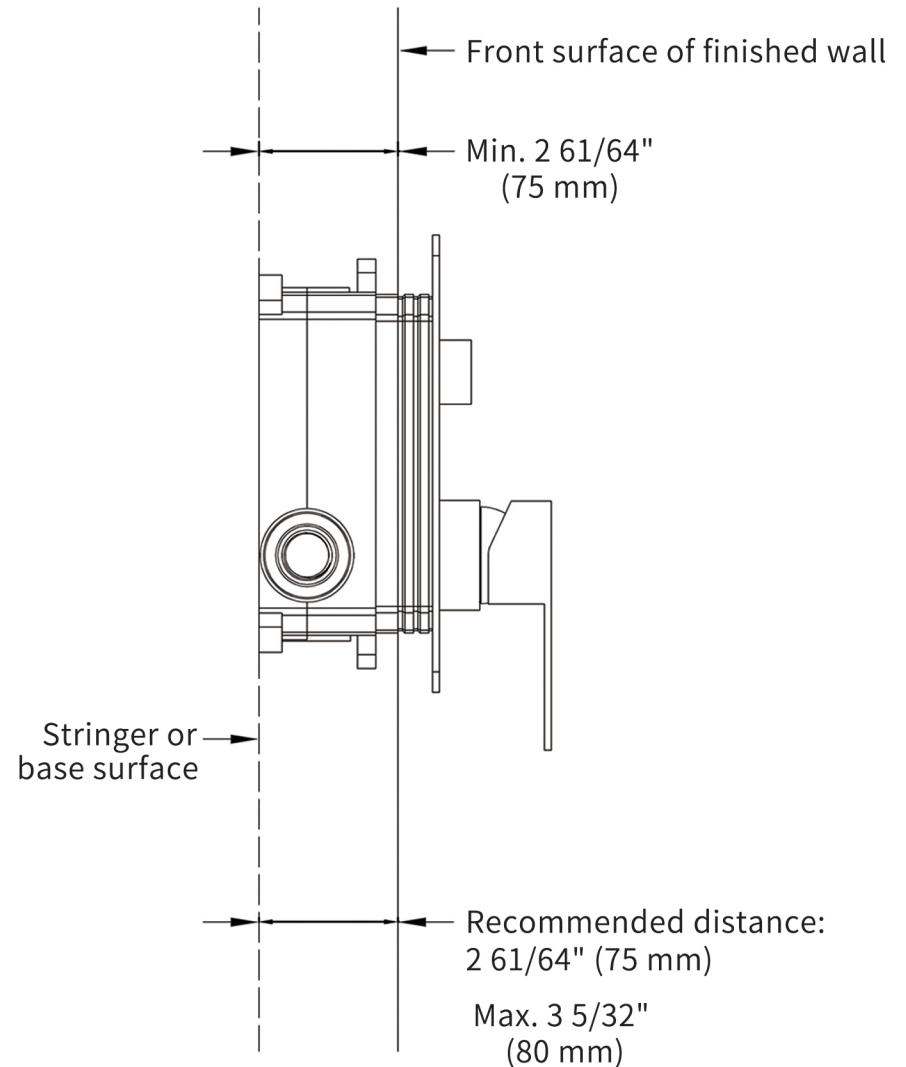

1. Rough Valve Installation

1.1

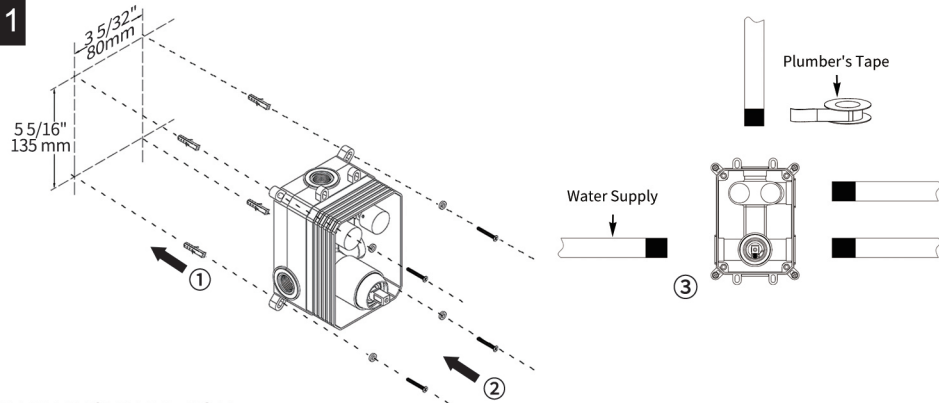

VALVE INSTALLATION

Notice: Turn off water supply before installation.

Step 1: For concrete wall, drill holes and place anchors into the holes.

Step 2: Attach valve box onto the wall or wood frame, secure it with screws.

Step 3: Connect valve with water supply (using plumber's tape to avoid leakage).

1.2

WATER TESTING

Install the handle and diverter knob, and then turn on to check for leakage.

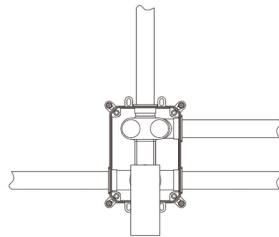

2. Trim Installation

2.1

Height Adjustment

You can adjust the height of the valve box by cutting excessive parts with a pair of pliers. Please refer to the recommended distance on the left.

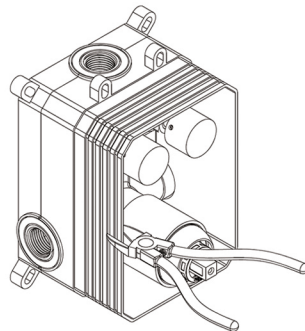

2.2

NOTICE:

1. You may need to apply plumber's tape on threads of shower arm and supply elbow.
2. Turn on water to check for leakage after installation.
3. You must adjust temperature limit stop seasonally to avoid water burns.
4. Removable flow restrictor: Water flow restrictor (2.5GPM) can be removed if your water pressure is low. Water flow can go up to 7.5 GPM without flow restrictor, please remember to check your local plumbing codes and regulations before removal.

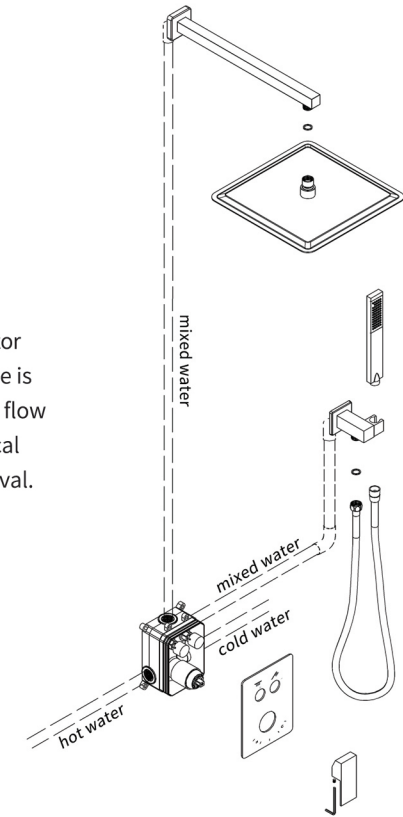

3. Temperature Limit Stop Adjustment

3.1

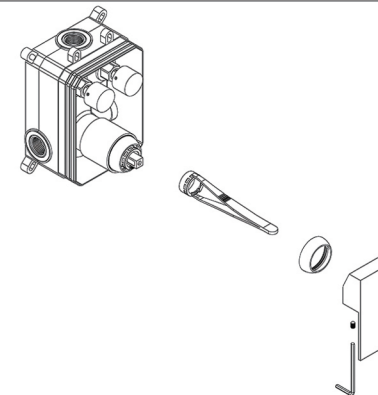

3.2

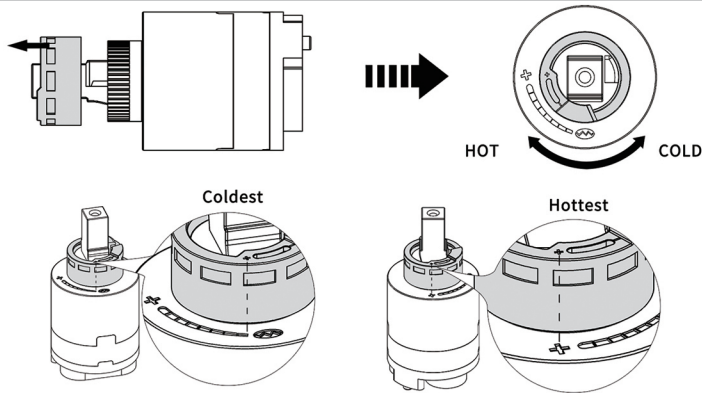

IMPORTANT : The Rotational Limit Stop is used to restrict the amount of hot water in the mix . By setting the Rotational Limit Stop properly , you can avoid scald injury if the handle is accidentally rotated all the way to " hot " . The First Position (shown in picture) allows the LEAST amount of hot water and is the coldest position . As you move the Rotational Limit Stop counterclockwise , you progressively add more and more hot water in the mix . You will have the greatest amount of hot water in the mix and the greatest risk of scald injury at The Last Position (shown in picture) counterclockwise.

Warning

Setting the Rotational Limit Stop in The Last Position or beyond The Last Position (counterclockwise) could result in scald injury. It is vital to adjust the Rotational Limit Stop to avoid scald injury to the user when the handle of the valve is rotated to the hot side. Please check your local plumbing codes for maximum water mix temperature (normally should not exceed 120°F). If inlet water temperature changes seasonally, you may need to readjust the Rotational Limit Stop. Recommended water temperature for bath or shower is between 90°F-110°F. Run the water so that the cold water is as cold as it will get and hot water is as hot as it will get. Place the handle on the cartridge stem and rotate the handle clockwise until the handle stops. Place a thermometer in a plastic tumbler and hold in the water stream. If the water temperature is above 120°F or the maximum temperature requirement of local plumbing codes (whichever is lower), the Rotational Limit Stop must be readjusted clockwise to decrease outlet water temperature.

Warning

MAKE SURE COLD WATER FLOWS FROM THE VALVE FIRST. MAKE SURE WATER FLOWING FROM THE VALVE AT THE HOTTEST FLOW POSSIBLE DOES NOT EXCEED 120°F OR THE MAXIMUM ALLOWED BY YOUR LOCAL PLUMBING CODES.

Caution

This system/device has to be set by the installer to ensure safe, maximum temperature. Any variation in the setting may raise the discharge temperature above the limit considered safe and may cause hot water burns.

Warning

This pressure balance valve does not control temperature, only pressure fluctuations. The Limit Stop does not control temperature variations caused by inlet temperature variations. Pressure balance valve will not provide protection from hot water burns when there is a failure of other temperature controlling devices elsewhere in the plumbing system. And if the Rotational Limit Stop is not set properly, the hot water temperature is changed after the Rotational Limit Stop is set, or if the water inlet temperature changes due to seasonal variations, it also may will cause hot water burns.

Notice to the installer

Caution!

As the installer of this valve, it is your duty to INSTALL and ADJUST this valve properly according to the instructions given. This valve does not adjust automatically for inlet temperature changes, further adjustments maybe necessary due to seasonal water temperature change.

YOU MUST inform the owner/user of this requirement by following the instructions. After installation and adjustment, you must affix your name, company name and the date you adjusted the Rotational Limit Stop to a label and apply or attach the label to the backside of the closet cabinet door and a warning label to the hot water heater. Leave this instruction sheet for the owner's/user's reference.

Lifetime Limited Warranty

Faucets

KES warrants its faucets purchased from authorized sellers to be leak and drip free as long as the original consumer owns their home in which the product was first installed (the "Warranty Period" for homeowners). For all other purchasers (including purchasers for industrial, commercial and business use) are warranted for a period of 3 years from the original date of purchase (the "Warranty Period" for non-homeowners).

Other Products

Products other than faucets are backed by a 1-Year Limited Manufacturer's Warranty (the "Warranty Period" for non-faucet products).

What We Will Do

If a faucet should ever develop a leak or drip during the Warranty Period, KES will FREE OF CHARGE provide the parts necessary to put the faucet back in good working condition.

For non-faucet products, KES will replace FREE OF CHARGE any part that proves defective in material and manufacturing workmanship during the Warranty Period.

If repair or replacement is not practical, KES may elect to refund the purchase price in exchange for the return of the product.

What Is Not Covered

KES shall not be liable for any damage to the product resulting from reasonable wear and tear, installation and maintenance errors, outdoor use, freezing water, abuse, misuse, and use of cleaners containing abrasive cleansers, ammonia, bleach, acids, waxes, alcohol or other organic solvents.

KES is not responsible for removal, installation, labor charges, or other incidental or consequential costs. In no event shall the liability of KES exceed the purchase price of the product.

KES AND/OR SELLER ARE PROVIDING THESE WARRANTIES IN LIEU OF ALL OTHER WARRANTIES, EXPRESSED OR IMPLIED, INCLUDING BUT NOT LIMITED TO THE IMPLIED WARRANTIES OF MERCHANTABILITY AND FITNESS FOR A PARTICULAR PURPOSE. KES AND/OR SELLER DISCLAIM ALL LIABILITY FOR SPECIAL, INCIDENTAL OR CONSEQUENTIAL DAMAGES.

Some jurisdictions do not allow the exclusion or limitation of incidental or consequential damages, so these limitations and exclusions may not apply to you. This warranty gives you specific legal rights and you may also have other rights which vary from jurisdiction to jurisdiction.

This warranty applies only to KES products sold in North America and Europe.

Contact KES

Email: cs@keshome.com

Online Contact: <https://www.keshome.com/chat>

Please provide:

- Dated proof of purchase;
- Description of the defect/fault;
- Picture or video showing the issue(s) (optional).

The logo for KES, featuring the letters "KES" in a bold, italicized, sans-serif font.

Keep Efficient Simple